

## Quad sites' gate driver test solution

It's a high-voltage / high-speed gate driver capable of driving N-channel MOSFETs and IGBTs in a half-bridge structure. High voltage processing techniques the device's high side to switch to 600V in a bootstrap operation.

### Features:

- Floating high-side driver in bootstrap operation to 600V
- Drives two N-channel MOSFETs or IGBTs in a half-bridge
- 290mA source/600mA sink output current capability
- Outputs tolerant to negative transients
- Internal low side gate driver supply voltage: 10V to 20V
- Schmitt triggered logic inputs
- Logic input ( HIN and LIN) 3.3V capability

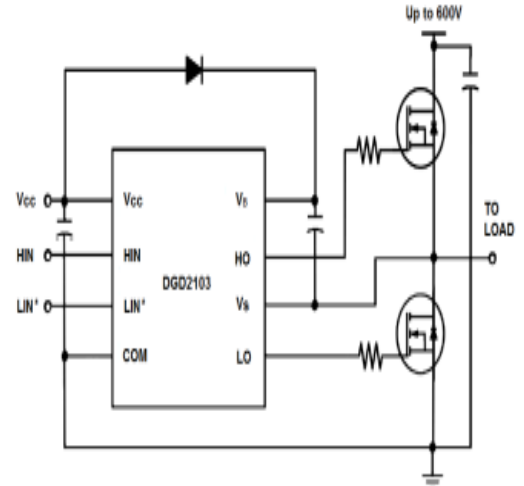

### 4 Sites' Test Configuration:

Module	FOVI	FVII1000	QTMU	CBIT	DIO32
Quantity	4	4	1	2	1

SineTest's test solution demonstrated our unique technology: mixed-using of analog and discrete test modules together to solve the complicated test.

- Tester model: STT-700X (13 slots)
- 4xFOVI provide 32 VI channels 50V/1A sources
- 4xFVII1000 provide 4 VI channels with 1000V/10mA to speed test time
- 1xDIO32(33Mhz) provides 16 I/O and 16 Out pins for logic input
- 1xQTMU provides 4 timing measurement unit
- 1xCBIT provides 144 control bits